



Rear Drop Sander



SPECIFICATIONS

- ◆ Bayonet style frame mount locks to rear frame pockets on MSV.
- ◆ Spreader drive motor is designed to handle up to 5 GPM at a maximum pressure of 2850 PSI and is driven by MSV rear hydraulics.
- ◆ Spreader controls are integrated into MDC and joystick controls. Drop rate is proportional to ground speed and automatically stops when vehicle stops.
- ◆ Integrated LED signal and back up lights.
- ◆ Capacity of spreader is ½ cubic yard.
- ◆ Empty weight is 275 lbs. Spreader design allows for easy removal and storage without the need for storage stands.
- ◆ Material can be spread continuously for up to 5 miles before sander must be refilled. Coverage extends to 10 miles when used in conjunction with the dump box.
- ◆ Spreader has one auger and one drop roll that are driven by an 11.3 cubic inch hydraulic motor via chain and sprocket.
- ◆ Heavy duty internal screen breaks up and prevents large clumps from plugging or damaging the auger.
- ◆ Lightweight cover with integrated tie-downs protects material and keeps moisture out.
- ◆ Front and rear underbody chassis weights recommended but not required for use with spreader.

MB Companies - MSV Sales

1615 Wisconsin Avenue / New Holstein, Wisconsin 53061

1-800-558-5800 / sales@m-bco.com

www.m-bco.com



Hydraulic Rear Drop Sander

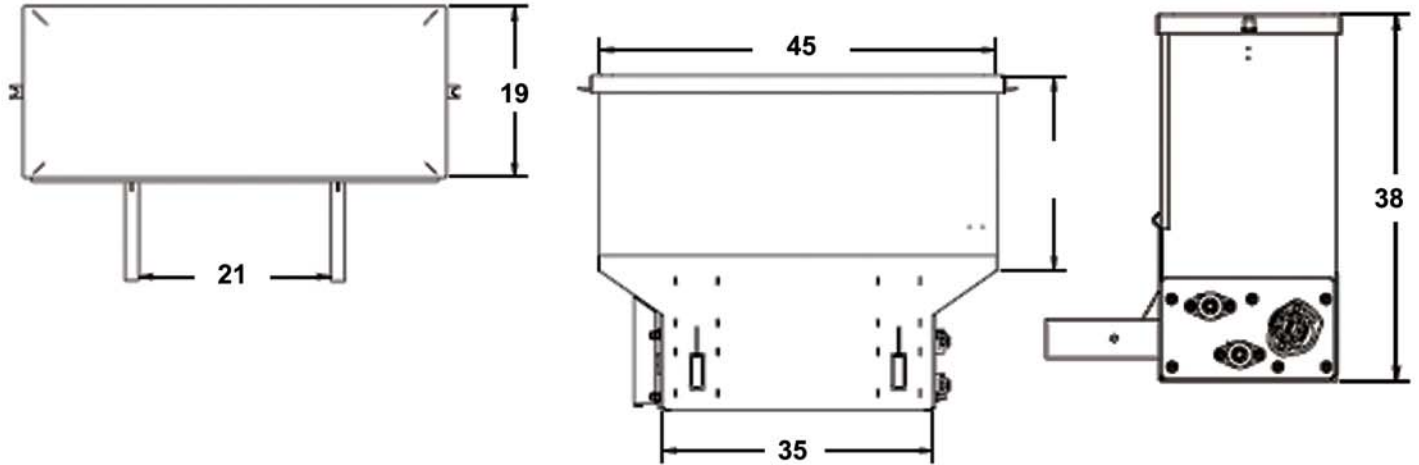

DISTRIBUTED BY:



MSV Sales
1615 Wisconsin Avenue
New Holstein, Wisconsin 53061
1-800-558-5800



In the interest of continual product improvement, M-B Companies, Inc. reserves the right to change specifications without notice. (8/2009)