



MB Companies, Inc. MSV Multi Service Vehicle

Operation and Maintenance Manual



*Model HP-SNB
PTO High Capacity Snowblower Attachment
for M-B Companies'
Multi-Service Vehicle (MSV)*

QUALITY YOU CAN SEE, PEOPLE YOU CAN TRUST™

Attachments Division, Brush Replacements, Administration

1615 Wisconsin Avenue
P.O. Box 200
New Holstein, WI 53061
Phone: 800-558-5800
Fax: 920-898-4588



Table of Contents

Safety	4	Storage	27
Hazard Definitions	4	Troubleshooting	28
Identification of Safety Labels	4	Operation.....	28
General Safety	4	Hydraulic System	29
Pre-Start-up Safety.....	5	Replacement Parts	30
Pressurized Systems Safety	5	Replacement Parts.....	30
The Manual	5	Auger with Reversing Valve.....	31
Required Operator Training.....	5	Auger without Reversing Valve.....	32
Work Area.....	5	Discharge Chute.....	33
Maintenance Safety.....	6	Snowblower with PTO	34
Welding.....	6	Hydraulic Fitting Installation	
General Information	7	Torque Recommendation	38
Introduction.....	7	Fastener Torque Recommendation	40
Machine Identification.....	7	Other Products from M-B/Warranty	43
Customer Service.....	7		
Attachment Information	8		
Introduction.....	8		
Specifications	8		
Dimensions.....	9		
Layout of Machine	10		
Installation & Setup	11		
Installation	11		
Setup	13		
Operation	16		
Connecting to the MSV	16		
Pre-start.....	17		
Starting Procedure	17		
Impact Protection	18		
Reversing Valve.....	18		
Loading Chute (Optional)	18		
Maintenance	19		
Discharge Chute Repair	19		
To Replace the Ribbon Assembly.....	21		
To Replace the Impeller Housing Liner	22		
Preventative Maintenance.....	23		
Lubrication Points.....	24		
Lubrication Chart	25		



Safety



WARNING:

Read this manual and any attachment owner's manuals before using this equipment. Failure to do so can result in serious injury or death. Call your dealer if you have any questions.

HAZARD DEFINITIONS

For your safety, and to assure the long life of your equipment, be sure you understand the following signal words which will be seen throughout this manual:

- **DANGER:** Alerts you to an immediate hazard, which will always result in severe personal injury and possible death if it is not avoided.
- **WARNING:** Alerts you to a hazard which will result in a serious personal injury or possible death in some cases, if not avoided.
- **CAUTION:** Alerts you to a potential hazard which may result in a serious personal injury if not avoided. It also alerts against an unsafe practice that will permanently damage equipment or property.
- **IMPORTANT:** Points out a proper use that will avoid damage to the machine, and/or will extend the life of its parts.
- **NOTE:** Suggests how to use or adjust the equipment for best product results.

IDENTIFICATION OF SAFETY LABELS

Safety labels are strategically located around the attachment to prevent potential hazards. The labels are a permanent part of the equipment. If they become separated from the product or illegible, contact M-B Companies Inc. for no-cost replacements. Understand the information the labels are communicating before operating or maintaining the equipment.

See Parts List section for safety labels associated with this equipment.

GENERAL SAFETY

- This manual should be available during operation.
- Extra copies of this manual are available for purchase through the M-B Customer Service Department.
- To avoid serious injury or death, do not modify equipment. Any modifications made to equipment can be dangerous and can void equipment warranty.
- Never defeat a safety device to make a task easier.
- Never deface or remove factory-installed safety labels. If a label ever becomes lost, damaged, or illegible, report this condition to a supervisor and obtain a replacement label from the Customer Service department of M-B Companies, Inc.
- Always wear proper apparel when operating equipment; safety glasses, face shield or goggles, ear protection, and dust mask. Tie hair back. Never wear loose clothing or jewelry that could get caught in moving parts.
- Never operate equipment with covers or guards removed. Rotating parts can cause severe injury. Keep hands, feet, hair, jewelry and clothing away from all moving parts.
- Understand the operation of hydraulic and pneumatic controls.
- Understand which adjustments are operator and which are maintenance adjustments.
- Always shut OFF equipment when left unattended.
- Never operate or work around equipment if under the influence of alcohol, drugs or medications.

PRE-START-UP SAFETY

- Install any covers or guards which may have been removed for shipping purposes.
- Before starting equipment, walk around equipment, making a visual inspection that all safety devices are properly installed and secured.
- Check that all hardware, fasteners, hydraulic fittings, etc. are in good condition and properly fastened. Replace any fatigued or damaged items with proper replacements.
- Personnel who are not required to be in the work area should be kept away. Never start the equipment unless you are absolutely certain that everyone in the area is clear of the machine and aware it is being started.
- Follow the manufacturer's recommended start-up procedure.

PRESSURIZED SYSTEMS SAFETY

- Do not disassemble a pressurized system unless properly trained and equipped with adequate tooling.
- Familiarize yourself with the proper method of relieving pressure from pneumatic or hydraulic systems. Never perform maintenance on, or disassemble, pressurized systems without first locking out power to these systems and then relieving pressure to them.
- Oils and fluids can be very hot under pressure. Use caution and allow the system to cool before beginning maintenance work.
- Never operate or pressurize one of these systems with worn or damaged components. Replace hoses, fittings, valves or other components which appear defective.
- Never adjust pressurized systems beyond recommended levels to achieve higher operating pressures.

THE MANUAL

It is the purpose of this manual to provide complete instructions for service, maintenance disassembly, repair, and installation of the mechanical components for the M-B Multi-Service Vehicle Snowblower Attachment.

Directional Reference

All reference to left, right, front, or rear are given from the operator in the operator position and facing the direction of your unit.

REQUIRED OPERATOR TRAINING

Original purchaser of this unit was instructed by the seller on safe and proper operation. If unit is to be used by someone other than original purchaser; loaned, rented or sold, ALWAYS provide this manual and any needed safety training before operation.

The Operator Must Understand:

- How to operate all controls
- The functions of all controls
- How to STOP in an Emergency
- Speed Ranges

WORK AREA

- ALWAYS check overhead and side clearances carefully before operation. ALWAYS be aware of traffic when operating along streets and curbs.
- Keep area of operation clear. Stay alert for hidden hazards.
- DO NOT run engine in an enclosed area. Always provide good ventilation.
- Abnormal Vibrations are a warning of trouble. Striking a foreign object can damage unit. Stop unit and engine. Wait for all moving parts to stop. Inspect unit and make any necessary repairs before restart.
- Protect eyes, face, and head from objects that may be thrown from unit. Wear appropriate hearing protection.
- Avoid Sharp Edges. Sharp edges can cause serious injury. Wear gloves to service unit when handling sharp edges.
- ALWAYS keep hands and feet away from all moving parts during operation. Moving parts can cause serious injury or death.
- Be aware of the surroundings. Look for blind spots from which pedestrians or vehicles may suddenly appear.
- Locate the emergency stop on the vehicle.
- Do not operate in crowded pedestrian areas. This equipment may cause serious injury or death if safety rules are not followed.
- The M-B Multiple Service Vehicle (M-B MSV) uses a level gauge. The gauge helps the operator determine the angle or slope of the surface being driven on. The gauge shows percent of grade.



WARNING:

During normal operation the M-B MSV must not exceed 30% grade to either side. Adding any attachment to the M-B MSV will affect the safe maximum grade.



Figure 1

MAINTENANCE SAFETY

- Do not remove guards while operating. After maintenance work, be sure all guards and other safety devices are installed and in proper working order.
- Never clean, lubricate, or adjust equipment while it is moving, has the potential to move or when engine is running.
- Always release pressure from pressurized systems before disassembling.
- Allow ample time for heated components to cool before working on or working close to them. Use temperature sticks or other appropriate devices to test temperatures.
- ALWAYS maintain unit in safe operation condition.
- Check the conditions of the unit at the end of each day and repair any damage or defects.
- Keep all fasteners properly torqued and in safe operating condition.
- Before maintenance, adjustments, or service (except where specifically recommended), shut off engine, and secure from moving.

Storage

ALWAYS clean and lubricate equipment before extended storage. Clean and lubricate equipment every 6 months during prolonged storage.

WELDING

Before welding on a machine/unit equipped with an electronic engine, the following precautions should be observed:

- Turn the engine control switch to the OFF position.
- Disconnect the negative battery cable at the battery. If a better disconnect switch is provided, open the switch.
- Connect the welder ground cable directly to the member to be welded. Place the ground cable clamp as close as possible to the weld to reduce the possibility of welding current damage to bearings, hydraulic components, electrical components and ground straps. Do not use electrical components, the ECM, or electronics ground stud for grounding of the welder.
- Protect wiring from welding debris or splatter.

General Information

INTRODUCTION

Thank you for choosing M-B Companies, Inc. as your equipment manufacturer and supplier. As part of our commitment to total customer satisfaction, we have strived to ensure that the information contained within this manual is complete and representative of the equipment you have purchased. The manual cannot, however, anticipate every possible contingency to be met in the installation, operation and maintenance for your equipment. If you require additional information not included in this manual, please contact our Service Department.

MACHINE IDENTIFICATION

Each machine manufactured by M-B Companies, Inc. has an identification plate mounted to it as shown in Figure 2. This plate contains the serial number of your M-B equipment. Copy the information from the plate on your equipment into the appropriate space in Figure 2. This information is important to have available when communicating with M-B.

CUSTOMER SERVICE

The serial number on your equipment is essential for proper service support. When contacting M-B Companies regarding service support, always provide the product serial number. This number is located on the identification plate mounted on your equipment, and should also have been recorded in the Machine Identification section.

Customer Service Department
 c/o M-B Companies, Inc.
 1615 Wisconsin Ave.
 PO Box 200
 New Holstein, WI 53061
 Phone: 1-888-558-5801 or 1-800-558-5800
 Fax: 920-898-4588



Figure 2



Attachment Information

INTRODUCTION

This section provides information that is specific to the M-B MSV. Each sub-section describes a component or system to give the reader a reasonable understanding of the topic. If a more in-depth knowledge is needed, contact M-B Companies Customer Support.

SPECIFICATIONS

Model HP 50"	
Width	50" (127 cm)
Height	80" (203 cm) Chute Down 92" (233.5 cm) Chute Up
Length	53" (134.5 cm)
Intake Height	43" (109 cm)
Operating Weight	1400 lbs (635 kg)
Impeller Diameter	29" (73.5 cm)
Auger Diameter	32" (81 cm)
Chute Discharge Rotation (Hydraulically Controlled)	195 Deg
Deflector Control	Hydraulic
Throw Distance	Up to 50 ft (15 m)
Tons Per Hour (Metric Tons)	700 (635)
Recommended Operating RPM	2200
Max Operating RPM	2700
Aux 3 Hydraulic Flow Settings @ 2200 RPM	Standard Flow (26 gpm pump) 15.9 gpm High Flow (31 gpm pump) 18.9 gmp

Model HP 60"	
Width	60" (152 cm)
Height	80" (203 cm) Chute Down 92" (233.5 cm) Chute Up
Length	53" (134.5 cm)
Intake Height	43" (109 cm)
Operating Weight	1600 lbs (725.7 kg)
Impeller Diameter	29" (73.5 cm)
Auger Diameter	32" (81 cm)
Chute Discharge Rotation (Hydraulically Controlled)	195 Deg
Deflector Control	Hydraulic
Throw Distance	Up to 50 ft (15 m)
Tons Per Hour (Metric Tons)	700 (635)
Recommended Operating RPM	2200
Max Operating RPM	2700
Aux 3 Hydraulic Flow Settings @ 2200 RPM	Standard Flow (26 gpm pump) 15.9 gpm High Flow (31 gpm pump) 18.9 gmp

DIMENSIONS

	A	B	C
51-inch	50.1"	80.92"	55.29"
60-inch	60.1"	80.92"	55.29"

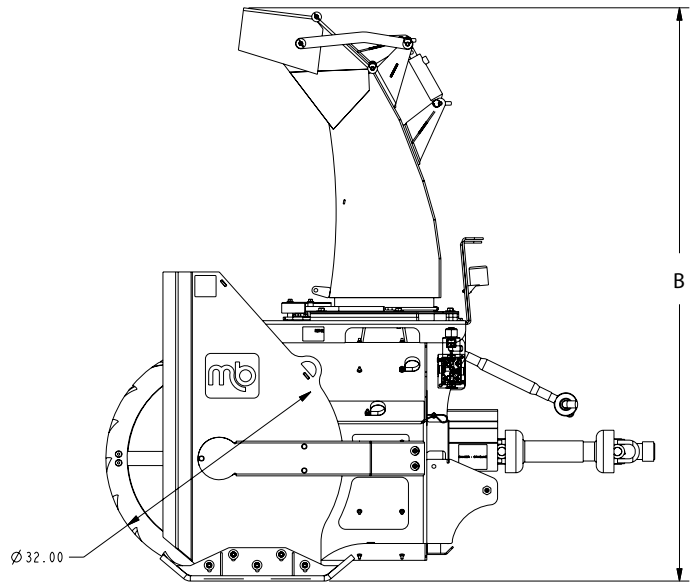
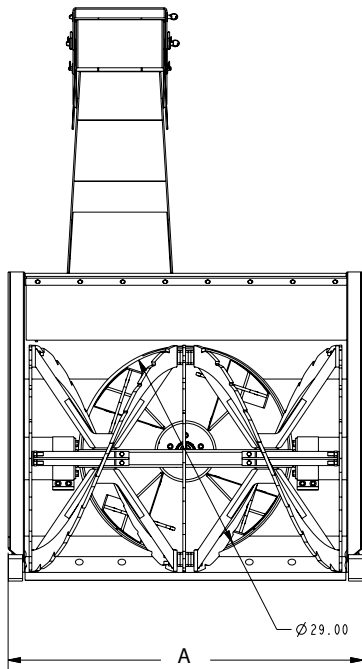
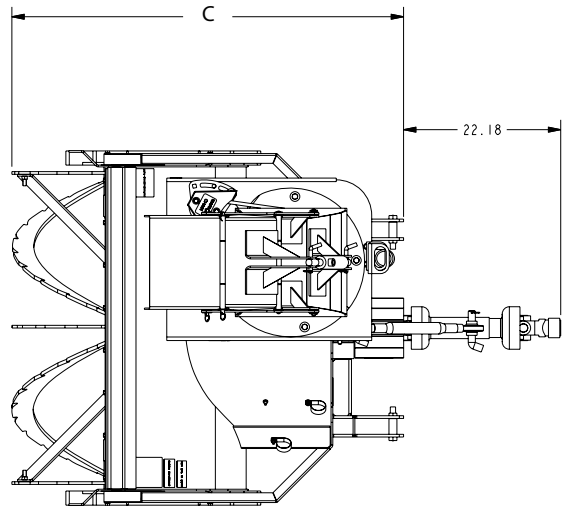

Figure 3



LAYOUT OF MACHINE

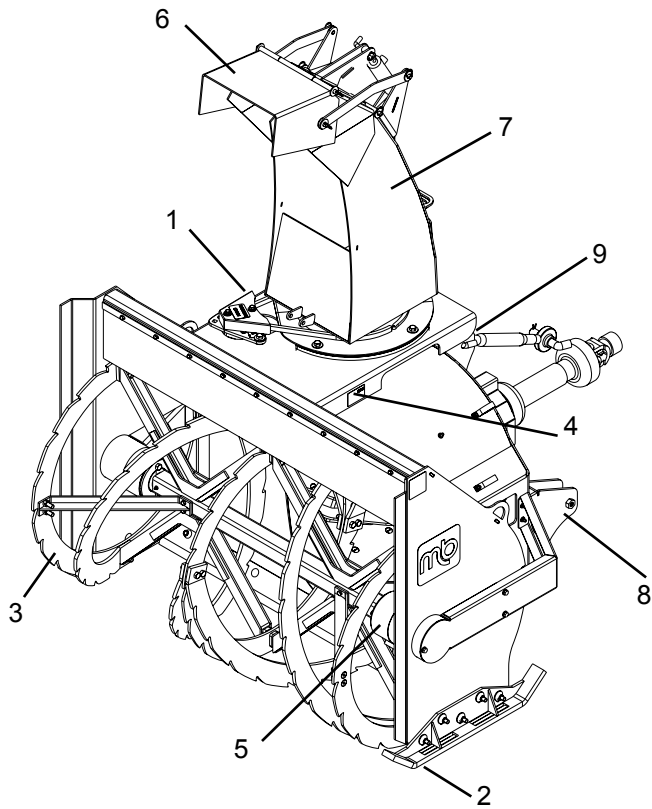

Figure 4

1. Chute Rotation
2. Skid Shoe
3. Ribbon Assy
4. ID Tag
5. Ribbon Drive Motor
6. Deflector
7. Discharge Chute
8. Lower Hitch Point
9. Upper Hitch Point

Installation & Setup

INSTALLATION

The HP-SNB snowblower attachment is connected to the MSV by a three-point hitch. Hydraulic connections to the MSV provide for chute rotation and ribbon (auger) drive power. A driveshaft connects the MSV power take-off (PTO) to the snowblower impeller.

1. Remove all components from the shipping crate and place in a secure location.
2. Remove the hairpin from the hitch pin and pull the hitch pin out to then remove the driveshaft guard from snowblower (Figure 5).

NOTE: Ensure the snowblower input shaft spline is greased.

Snowblower Impeller
Input Shaft

Driveshaft Guard



Figure 5

The telescoping driveshaft has a quick connect/disconnect collar on each end. The end of the driveshaft with the shear pin flange connects to the snowblower.

3. Place the end of the driveshaft on the snowblower input shaft. Pull back on the collar and push the shaft on completely. Release the collar and pull back on the shaft to ensure it is properly secured on shaft (Figure 6).

Connect/Disconnect
Collar

Shear Pin Flange

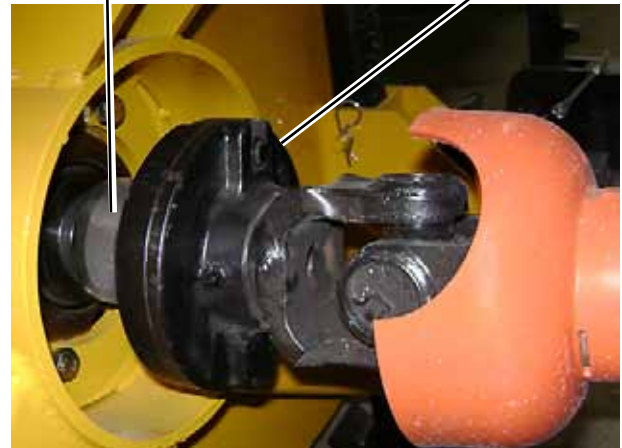

Figure 6

4. Install the driveshaft guard on snowblower and secure with hitch pin and hairpin (Figure 7).

Hitch Pin

Driveshaft Guard



Figure 7

5. Compress (shorten) the driveshaft which will help to connect it later to the MSV
6. Adjust the MSV lower hitch clamps to be centered and at the same width as the snowblower lower hitch pins. Tighten the lower hitch clamps to secure them in position on the MSV.



CAUTION:

Snowblower must be centered on MSV or damage may occur. The lower hitch clamps must be tightened in place.

- 7. Pull safety pin out of each hitch clamp. Pull hitch clamp levers forward to unlock. Insert safety pins to secure clamps (Figure 8).

Safety Pin MSV Lower Hitch Clamp Snowblower Lower Support Pin

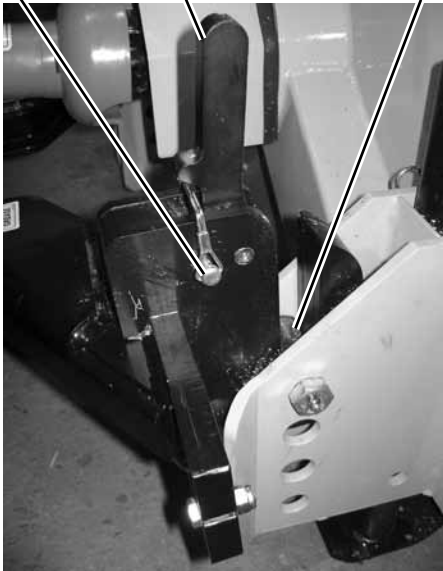

Figure 8

- 8. Drive the MSV forward and lift hitch to engage with the snowblower lower support pins.
- 9. Pull safety pin out of each hitch clamp. Push hitch clamp levers backward to lock. Insert safety pins to secure clamps (Figure 8).
- 10. Connect the top link to the MSV Hitch.

IMPORTANT: The snowblower attachment should be level front to rear when attaching the top link to the MSV. The top link is adjustable and is used to complete the leveling process. For leveling adjustments, refer to Setup.

MSV Lower Hitch Clamp Snowblower Lower Support Pin

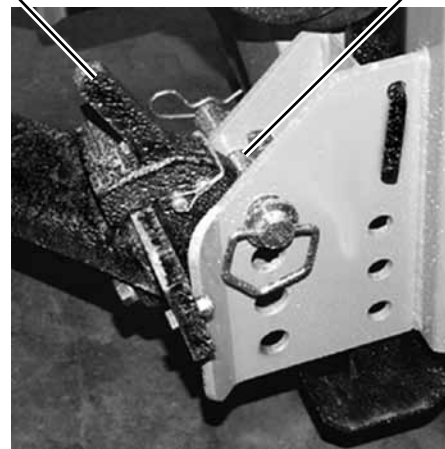

Figure 9

- 11. Unlock and remove the hatch in the MSV cab floor to provide access to the PTO connection (Figure 10).

NOTE: Ensure the PTO shaft spline is greased.

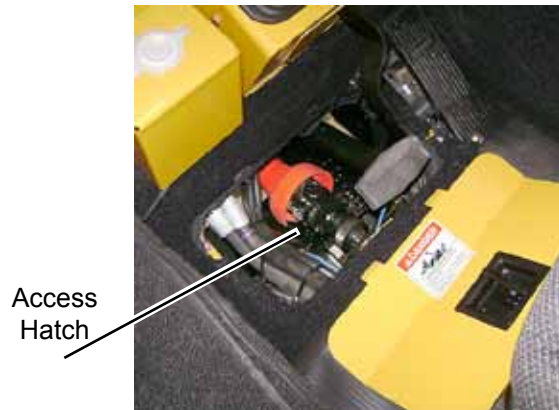

Figure 10

- 12. Pull the driveshaft to lengthen it if necessary and place it over the MSV PTO shaft spline. Pull back on the collar and push the shaft on completely. Release the collar and pull back on the shaft to ensure it is properly secured on PTO shaft (Figure 11).

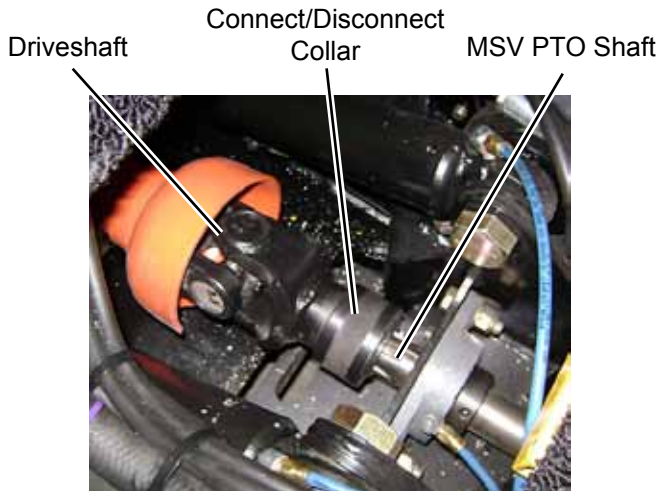

Figure 11

13. Install and lock the access hatch (Figure 10). The front of the MSV has several connections for hydraulic hoses. The operator controls in the MSV cab will be setup to use the auxiliary hydraulic connections. Refer to the MSV Operator's Manual for the quick disconnect fittings specifications.

Make the following snowblower hydraulic connections (Figure 12):

- Chute rotate connections to Aux 1.
- Deflector up/down connections to Aux 2.
- The ribbon drive connects to Aux 3.

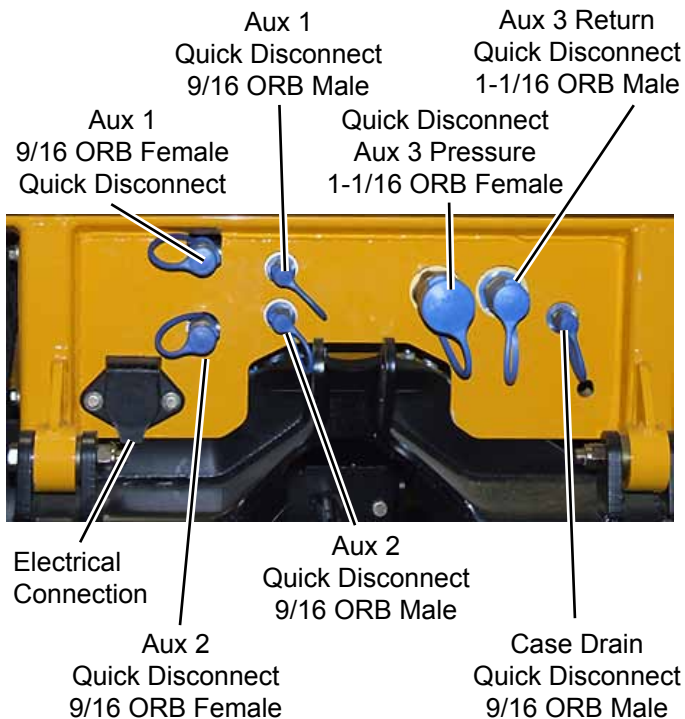

Figure 12

SETUP

Proper setup of your snow blower will increase the life of the components and produce more efficient movement of material. Visually inspect the adjustments before each operating session and measure the adjustments once every 10 hours of operation.

Front-To-Rear Leveling

See Figure 13.

1. Park the MSV with snowblower on a hard, flat, level surface; preferably concrete or asphalt.
2. Strike the locking tab counterclockwise (CCW) to break it loose and screw it away from the top link body (Figure 13).

NOTE: Turn the body clockwise (CW) to shorten the top link, tipping the snowblower rearward. Turn CCW to lengthen the top link, tipping the snowblower forward.

3. Turn the body as necessary to shorten/lengthen the top link. The included rod can be inserted into the center hole in the body and used as a lever for turning.
4. Continue to adjust the length of the top link as necessary until the snowblower is level front to rear.
5. Turn the locking tab CW against the link body. Strike the tab CW to lock it in place against the body.

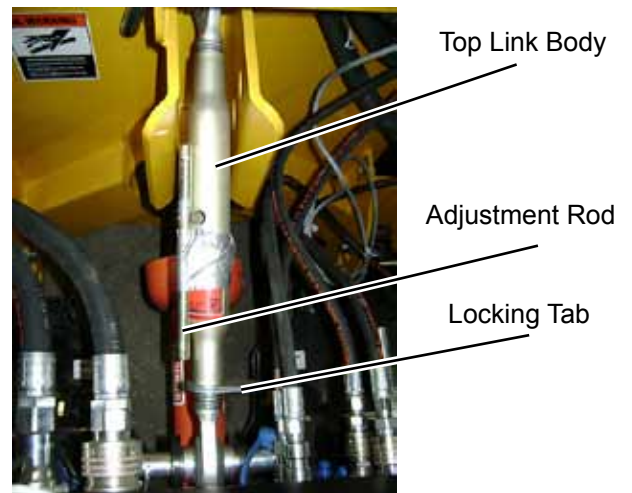

Figure 13



Scraper Height Adjustment (Side-To-Side Leveling)

The height of the scraper blade (cutting edge) will determine the quality of snow removal. The scraper blade mounting position is fixed and cannot be adjusted. The position of the skid shoes is adjusted vertically to change the scraper blade height.

If the skid shoes are positioned too far down, the scraper blade will not clear all the snow. If skid shoes are set too high, the scraper blade will wear and allow the ribbon (auger) to make contact with the ground. Mismatched skid shoe heights will cause uneven clearing of snow.

See Figure 14.



WARNING:

When adjusting the skid shoes, the MSV engine must be OFF if the snowblower is connected. For additional safety, disconnect the hydraulic hoses from the HP-SNB Snowblower to the MSV.

1. Park the MSV with the mounted snowblower on a hard, flat, level surface; preferably concrete or asphalt.

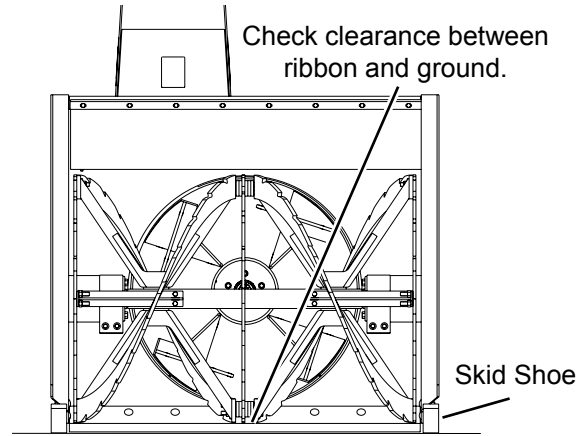

Place shims between ground and scraper blade.

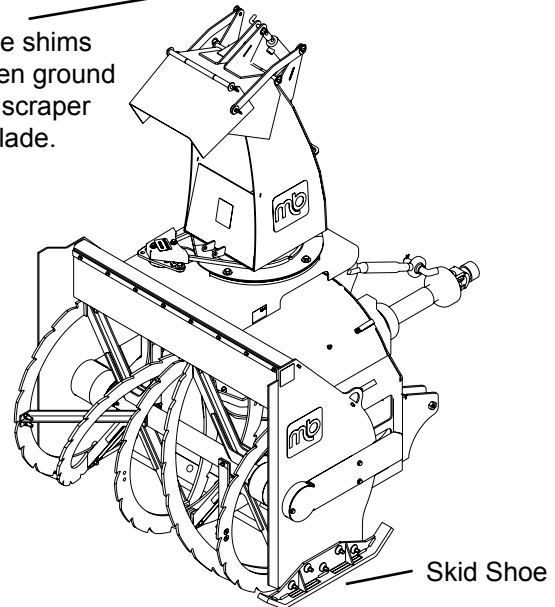

Figure 14

2. Raise snowblower high enough to allow placement of shims listed in step 3.

If using the snowblower on gravel or uneven surfaces, a minimum gap of 1" (25mm) is recommended to minimize the scraping of unwanted debris. This will help avoid running gravel through the snow blower. Allow 1/8" (3 mm) between scraper blade and hard, smooth surfaces. Use appropriate shims when adjusting height.

3. Place shims between scraper blade and hard, smooth ground surface.
4. Lower snowblower onto ground/shims.
5. Shut off snowblower and MSV. Remove MSV key from ignition and apply parking brake.
6. Loosen the five 1/2"-13 locknuts and carriage bolts for mounting each skid shoe.

7. Push the skid shoes downward to make solid contact with the ground. Tighten all mounting locknuts and bolts.
8. Remove shims from below scraper blade.
9. With the skid shoes on the ground, check the clearance between scraper blade and ground surface. The ribbon must not be in contact with ground.

NOTE: The skid shoes have a carbide blade attached to the bottom. If the carbide is wearing unevenly the skid shoes can be reversed and mounted on the opposite sides. When the carbide blade is worn off, the skid shoes must be replaced.

Chute Rotation Chain Adjustment

See Figure 15.

1. Loosen two 1/2" hex head capscrews securing motor mounting plate to snowblower housing.

IMPORTANT: Chain should not be overly tight, which could prevent free rotation of chute. An open span of chain should deflect approximately 1/4".

2. Rotate motor mounting plate back in slot to tighten chain.
3. Tighten two 1/2" hex head capscrews to secure motor mounting plate to snowblower housing.

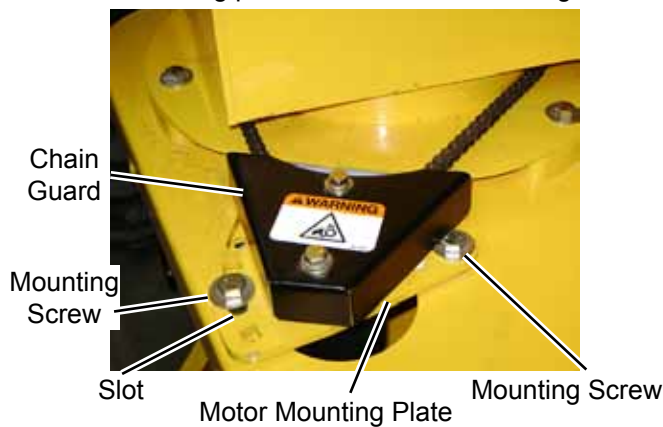

Figure 15



Operation

CONNECTING TO THE MSV

The Snowblower attachment is connected to the MSV by a three-point hitch. Hydraulic connections are used to position the chute and drive the ribbon. A power take-off shaft (PTO) turns the second stage.

Joystick Layout - Snowblower

The joystick layout screen in the attachment section of the MDC is used to display all the joystick functions when the Snowblower attachment is used. Use the Attachment Selection screen to change Default to Yes (Figure 16). The joystick functions will perform as shown in Figure 17.

If the Spreader and/or other rear attachments will also be mounted on the M-B MSV, other selections may be used. The joystick functions will perform as shown in Figure 18 through Figure 21.

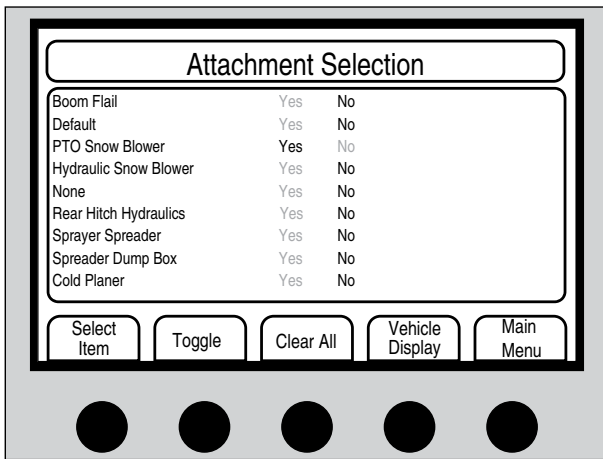

Figure 16

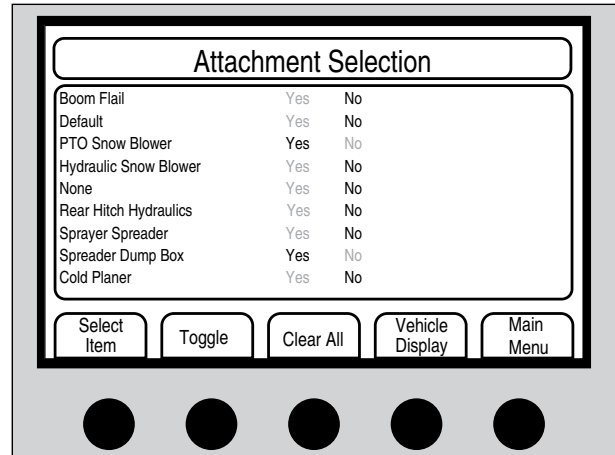

Figure 18

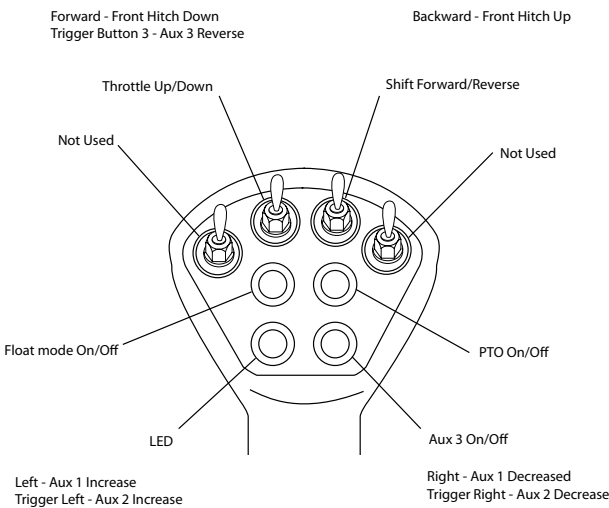

Figure 17

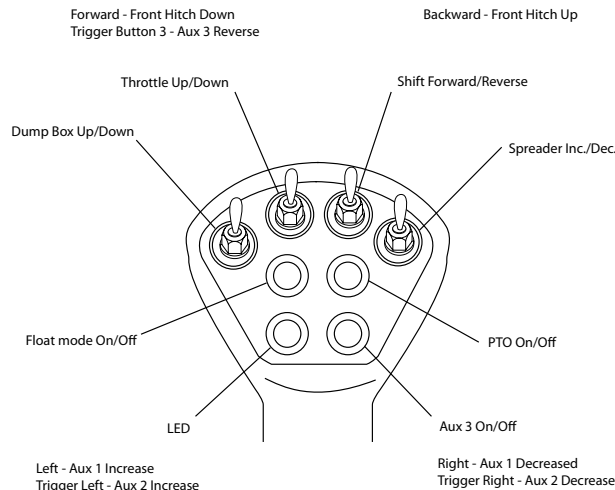

Figure 19

Use the Attachment Selection display, highlight Default and Rear Hitch Hydraulics. Toggle both to Yes.

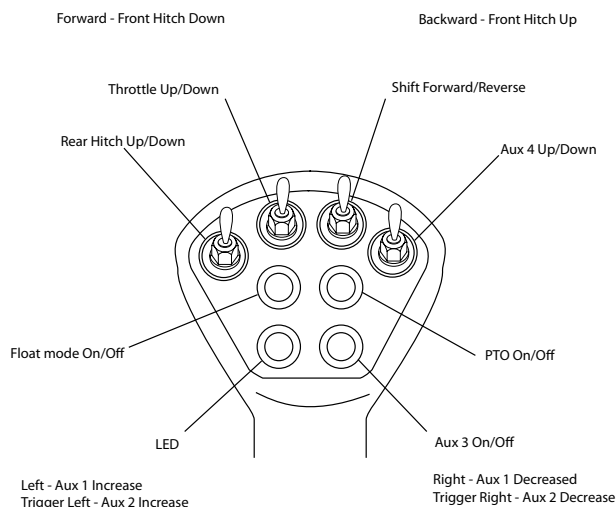

Figure 20

Use the Attachment Selection display, highlight Default and Sprayer Spreader. Toggle both to Yes.

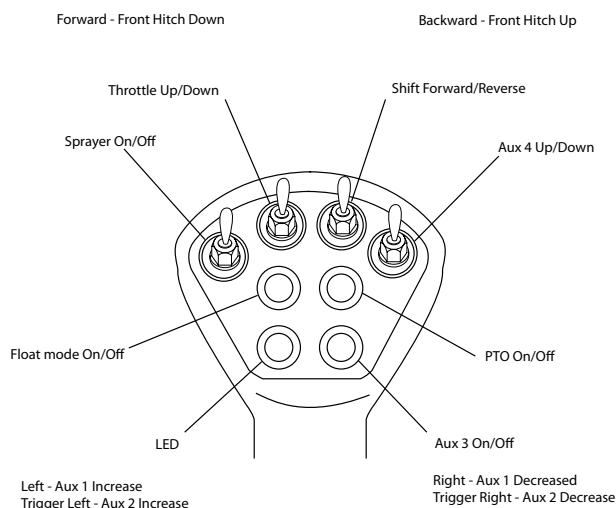

Figure 21

PRE-START

IMPORTANT: You must read, understand and comply with all the safety and operating instructions in this manual before attempting to start and operate the HP-SNB Snowblower.

Failure to comply with the safety and operating instructions can result in loss of machine control, serious personal injury to you and/or bystanders, and risk of equipment and property damage.

Before starting the snowblower:

1. Visually inspect equipment and hardware to ensure that all parts are secure and all hardware is tightened and secure.
2. Check for oil leaks and loose hose connections.
3. Inspect the snowblower to ensure all adjustments are correct. Refer to the Setup section.
4. Inspect the scraper blade (cutting edge) to determine if replacement is necessary.

IMPORTANT: The support stands should never be used for anything other than as stationary supports to hold the snowblower level while it is being stored.

5. Ensure the support stands are raised to the highest position and secured in place.
6. Review the Specifications section to determine the proper Aux 3 hydraulic settings and recommended operating RPM's.

STARTING PROCEDURE

- To start using the Snowblower:
- Review Specifications chart to determine proper Aux 3 hydraulic settings and recommended operating RPM's.
- The MSV should be running.
- Select PTO Snow Blower in attachment section of the MDC (Monitor Diagnose Control).
- The RPM of the engine must be less than 1250 RPM to engage the PTO shaft and the hydraulic ribbon.
- The MSV should be in either work mode or crawl mode.
- The operator must have the seat belt on.
- The joystick will control snowblower function using PTO, Aux 1, 2 and 3.



IMPACT PROTECTION

Hitting a foreign object with the rotating ribbon causes severe impact to the drive system. The MB Snowblowers have two features that protect the unit.

- The hydraulic drive for the ribbon has a pressure relief valve located on the blower manifold. There is also a higher pressure relief for Aux 3 located on the MSV. At impact the valve opens allowing the hydraulic fluid to bypass the motor stopping the ribbon instantly.
- The PTO drive shaft has a shear bolt that will break in the event of a major impact. The flanged end of the PTO has a set of holes that line up. The shear bolt will go through the two flanges and a locking nut should be used on the bolt threads. The shear bolt is a unique design and must not be replaced with a standard bolt.

IMPORTANT: The shear bolt must not be tight on the flanges. Tightening the flanges together will override the shearing of the bolt. Damage to the moving parts is likely.

REVERSING VALVE

The snowblower is equipped with a reversing valve that allows the auger to be reversed. When the auger becomes plugged, reverse the auger for a short time to push material out. Do not leave the auger in reverse for an extended time.

To reverse the auger, hold the joystick trigger in while starting Aux 3.

LOADING CHUTE (OPTIONAL)

An optional loading chute is available. The chute replaces the deflector. When it is in place the loading chute will clear a height of 10.5 feet. When the MSV is not moving snow the loading chute can be lowered for faster travel.



Figure 22



Figure 23

Maintenance

The MB Snowblower should be kept clean. All bearings are sealed and require no maintenance.

WARNING:
 To prevent serious injury never perform maintenance on the equipment while the MSV engine is running, or the hydraulic hoses are connected.

To remove hydraulic hoses that have STC (Snap To Connect) fittings a removal tool should be used. Install removal tool (part FIX157751) as shown in Figure 24. Pry the tool against the hose. Pull the fitting off the hose end (Figure 25).



Figure 24



Figure 25

DISCHARGE CHUTE REPAIR

The discharge chute is rotated using a hydraulic motor and a drive chain. The deflector is raised/lowered using a hydraulic cylinder.

The chute rests on a plastic bearing. Keepers shaped like a "C" are used as spacers to provide clearance. Bearing plates are bolted through the keepers to clamp the chute bearing in place while allowing the chute to rotate.

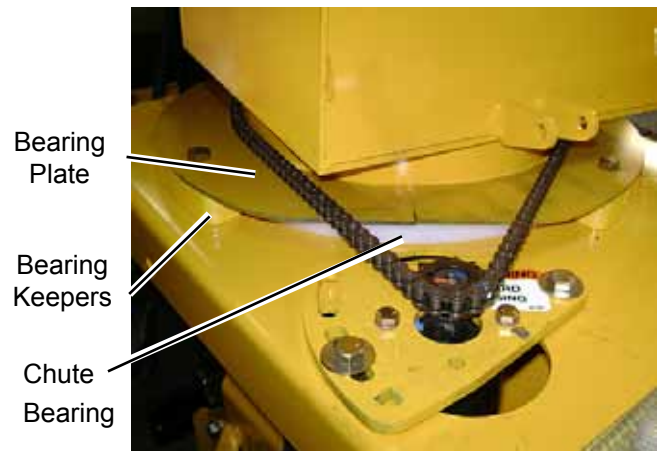

Figure 26

WARNING:
 The discharge chute is top heavy and will fall over. When performing maintenance on the chute use a lift device to support the weight of the chute.



To disassemble the discharge chute (Figure 27 and Figure 28):

1. Remove cover from chain drive motor
2. Loosen drive motor mounting bolts (Figure 27)

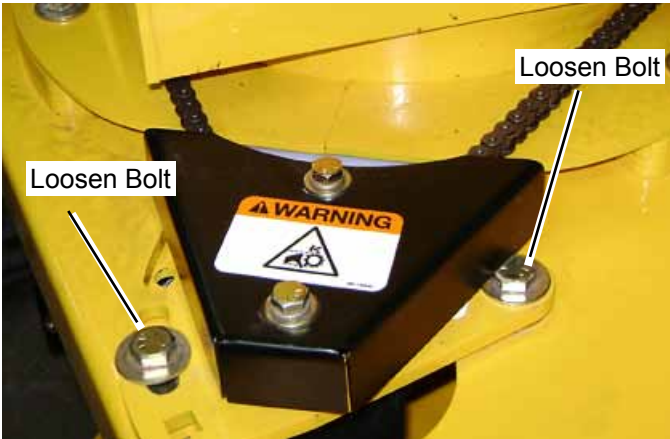

Figure 27



WARNING:

The weight of the discharge chute must be supported by a lifting device.

3. Remove the drive chain by shifting the drive motor.

NOTE: The hydraulic hoses for the deflector may be removed to assist with removal of the chute.

4. Remove the two bearing plates and the chute can be lifted from the body.

5. Repair/replace parts as needed.

NOTE: The chute bearing should be cleaned and spray grease applied.

6. Reassemble in reverse order

7. Adjust the tension on the chain by moving the drive motor back. Tighten the adjusting nut (Figure 27).

IMPORTANT: Do not pull the chain tight. The chain should deflect approx. 1/4-inch.

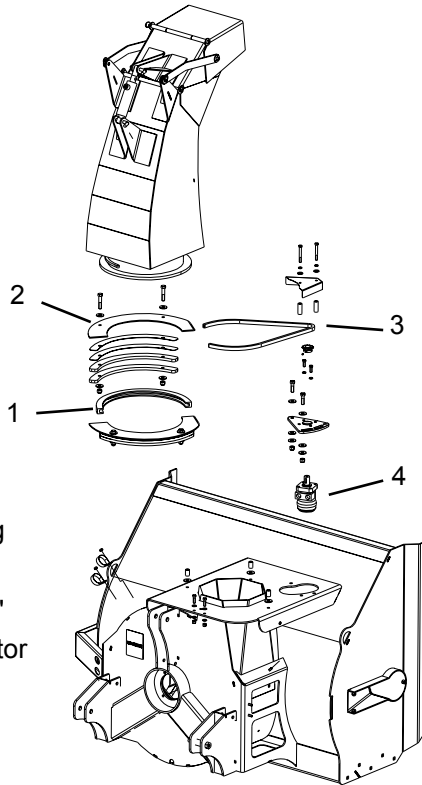

1. Chute Bearing
2. Bearing Plate
3. Chain #40-52"
4. Hyd Drive Motor

Figure 28

TO REPLACE THE RIBBON ASSEMBLY

NOTE: A lifting device will be needed to support the ribbon when mounting bolts are removed.

To remove the ribbon assembly:

1. Remove the access collars over the drive motors on both sides (Figure 29).

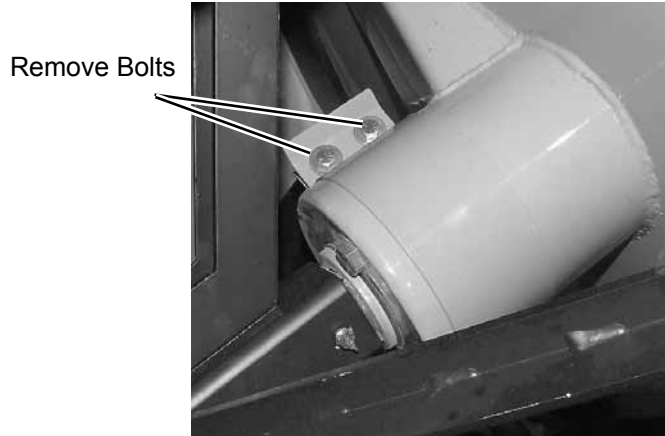

Figure 29



Figure 30

2. When the covers are removed access openings at the top and bottom will enable a nut to be held with a wrench (Figure 30).
3. Remove one of the side covers located on the outside of the ribbon housing (Figure 31). This allows the motor to pull back.
4. On the same side unbolt and remove the outer ring from the ribbon.
5. Support the weight of the ribbon. Remove the bolts from both sides (Figure 30).



CAUTION:

When the drive motor is pulled back the ribbon will pull free.

6. Pull the drive motor back and remove the ribbon assembly (Figure 31).

IMPORTANT: When replacing components or the complete ribbon assembly the angle of the ribbon blades must be maintained. The bottom of the ribbon will move snow to the center and back into the impeller.

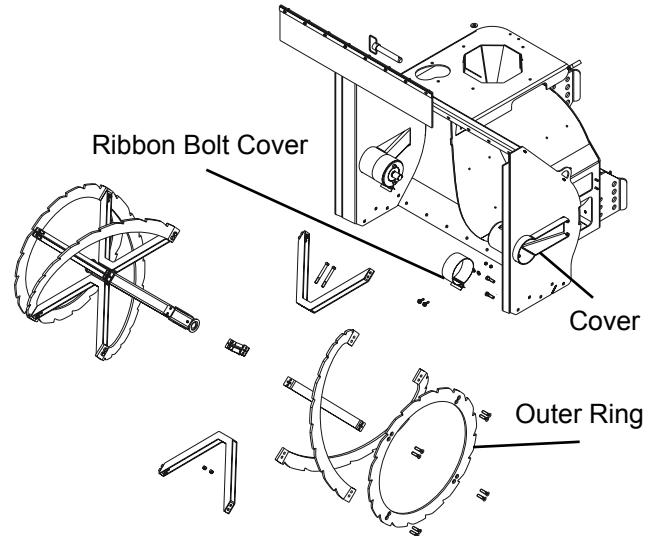

Figure 31



TO REPLACE THE IMPELLER HOUSING LINER

NOTE: The ribbon assembly should be removed. The impeller weighs 125 lbs (57kg).

To remove the impeller liner:

1. Remove the ribbon assembly (see above To replace ribbon assembly).



CAUTION:

The impeller may fall forward when the mounting bolts are removed. Support the impeller [125 lbs (57 kg)] when removing the bolts.

2. Remove the five bolts at the center of the impeller (Figure 32).



Figure 32

3. Remove the impeller by pulling outward.
4. Remove all the bolts that hold the liner in place. Remove the old liner.
5. Thoroughly clean the impeller/liner area.
6. Insert the new liner with the correct edge at the top (Figure 33).

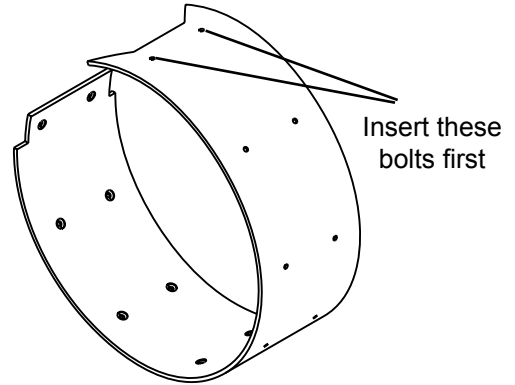

Figure 33

7. Insert the first two bolts at the top. Tighten until snug not tight.
8. Move in a right hand rotation (clockwise) and insert the remaining bolts and tighten until snug.
9. When all the bolts are in place they can be tightened.



CAUTION:

Fastener heads that are above the surface of the liner may interfere with the impeller and cause damage. Be certain to use the correct bolts and tighten completely.

10. Inspect the impeller for damage, repair as needed. Reinstall the impeller.
11. Reinstall the ribbon assembly (see above, To replace ribbon assembly).

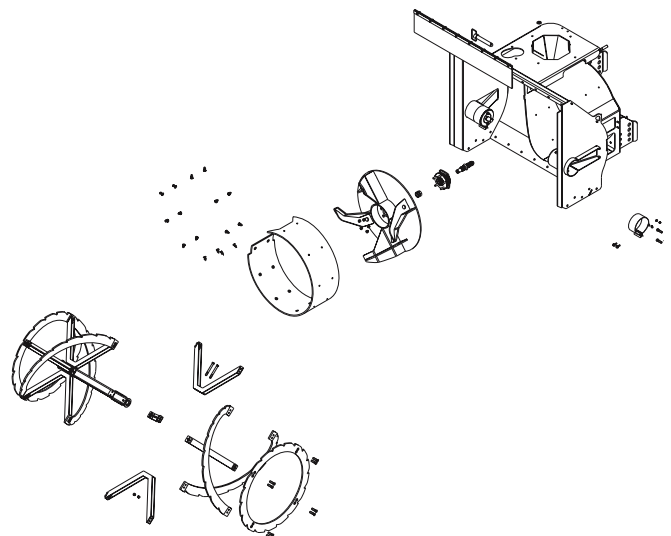

Figure 34



LUBRICATION POINTS

General Lubrication

IMPORTANT: Wipe Each fitting clean before and after lubrication.

Apply grease to the lube fittings.

Apply oil at all pivot points and pin connections, see Figure 35.

Unit should be lubricated at beginning of season or every 25 operating hours. See Maintenance Schedule.

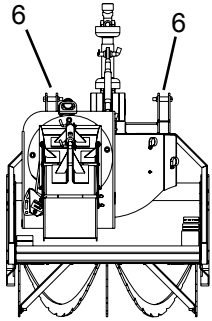

1. Ribbon Shaft
2. Chain Drive, Chute
3. Pivot Points
4. Chute Plate
5. PTO Drive Spline
6. Connection Pins

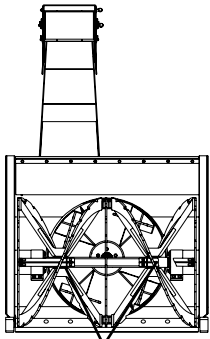

1
4 Points

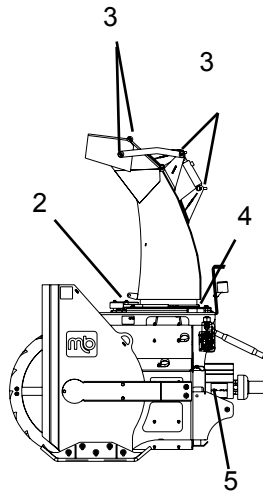
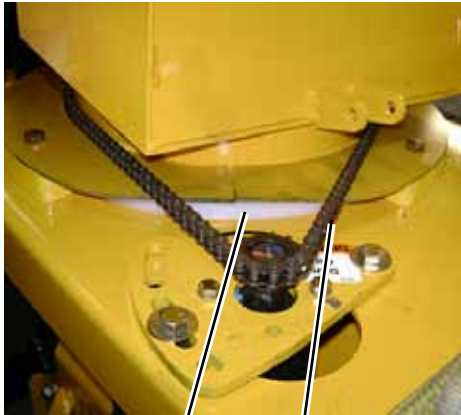

Figure 35

LUBRICATION CHART

Locations Refer to	Number of Locations	Refer to Figure #	Frequency				Lubrication Type		
			Before Each Use	Daily	Weekly	Monthly	Annually	MOBILUX EP2 Type Grease	Spray Grease
1. Ribbon Shaft	4	Figure 37				x		x	
2. Chain Drive, Chute	1	Figure 36			x				x
3. Pivot Pins	10	Figure 39			x				x
4. Hitch Lift Pins	2	Figure 43		x					x
5. PTO Drive Spline	1	Figure 38	x					x	
6. Chute Plate	1	Figure 36			x				x
7. Impeller Input Shaft Splines	1	Figure 40	x						x
8. Impeller PTO Driveshaft	1	Figure 41		x					x
9. Top Link End Joints	2	Figure 42		x					x



6 2

Figure 36

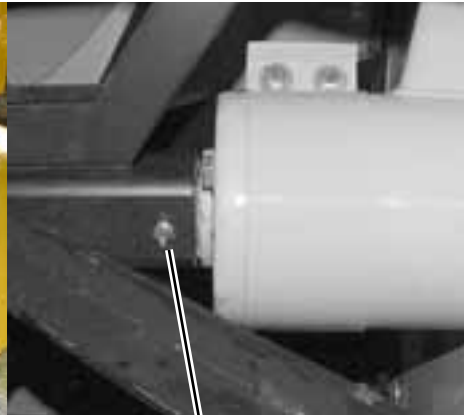

1

Figure 37

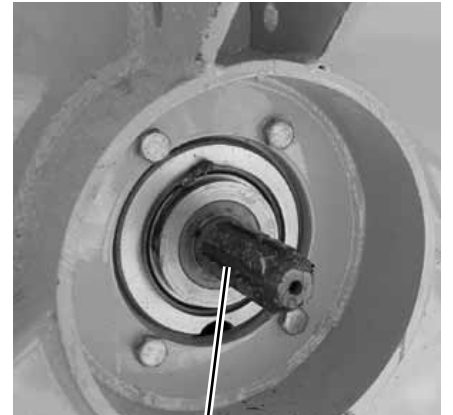

5

Figure 38

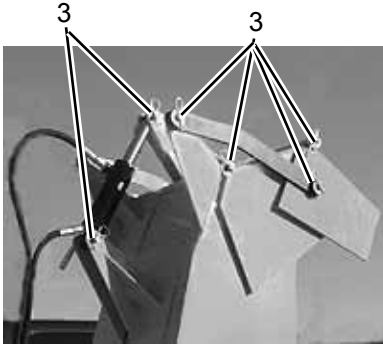

Figure 39

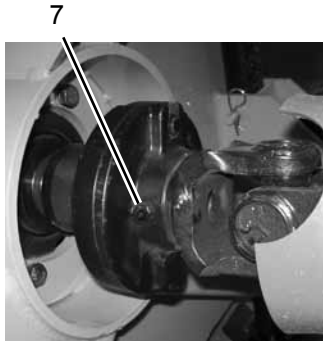

Figure 40



Figure 41

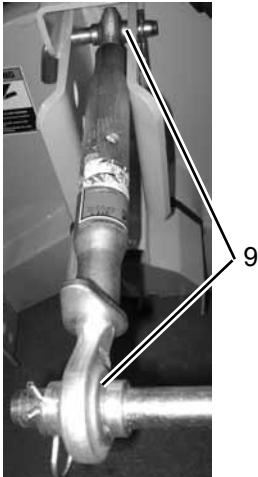

Figure 42

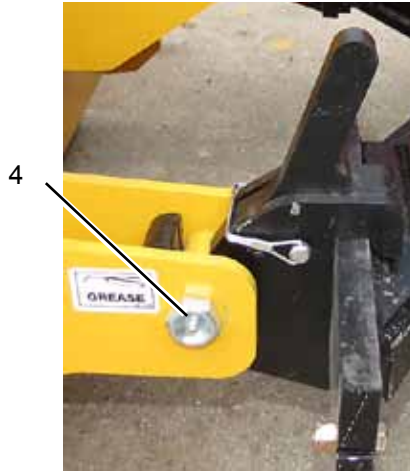

Figure 43

Storage

- Store the unit in a supported position with the cutting edge off the ground, such as on a wooden skid. If stored on the ground, the components are subjected to more moisture which can accelerate rusting.
- Properly drain hydraulic hoses or cap off to prevent spillage of oil. Clean up any spills quickly and appropriately.
- Connect Quick couplers together if disconnecting snowblower from MSV to allow fluid to circulate.
- Disconnect all electrical connections between the snowblower and MSV for extended storage to prevent battery drain.
- Properly clean the unit before storage, removing dirt, gravel, salt, etc. to extend paint life.
- If the unit is power-washed, all lubrication points should be greased or oiled before storage.



Troubleshooting

OPERATION

Problem	Probable Cause	Corrective Action
Ribbon does not rotate.	MSV engine not running.	Start MSV.
	Low hydraulic oil level.	Add hydraulic oil to MSV.
	Hydraulic hoses not connected.	Check hose connections.
	Key missing/broken on ribbon motor drive shaft.	Inspect and replace key.
	Ribbon hydraulic drive motors installed improperly or seized/damaged.	Inspect motors and install or repair as necessary.
	Ribbon bent.	Disassemble, inspect and repair/replace as necessary.
Impeller does not rotate.	PTO driveshaft not rotating.	Check driveshaft connections. Check if driveshaft shear pin is broken. Check operation of MSV PTO.
	Impeller support bearing seized.	Replace bearing as necessary. Properly lube bearing.
Discharge chute does not rotate.	MSV engine not running.	Start MSV.
	Low hydraulic oil level.	Add hydraulic oil to MSV.
	Hydraulic hoses not connected.	Check hose connections.
	Hydraulic drive motor installed improperly or seized/damaged.	Inspect motor and install or repair as necessary.
	Chain bound, stuck or damaged.	Inspect, clean and replace if necessary. Adjust chain tension for smooth operation. Refer to the Chute Rotation Chain Adjustment procedure within the SETUP AND ADJUSTMENTS section.
	Chain connector links or clips missing or broken.	Replace as needed.

Problem	Probable Cause	Corrective Action
Snowblower discharging poorly or clogging.	Material is frozen on ribbon, impeller or inside snow blower housing.	Slow down MSV forward speed. Stop, back up, shut down MSV completely and remove debris.
	Uneven ground surface.	Adjust skid shoes height to allow more clearance. Refer to the Scraper Height Adjustment procedure within the Setup section.
	Material is too heavy.	Take a smaller swath of material at a time.
	Forward motion too fast.	Slow down MSV forward speed.
Scraper blade (cutting edge) or skid shoe wearing unevenly.	Improper height adjustment for terrain type or uneven adjustment of skid shoes.	Adjust skid shoes height to allow more clearance. Refer to the Scraper Height Adjustment procedure within the Setup section.
Snowblower producing excessive vibration.	Caked-on debris or object in ribbon or impeller.	Shut down MSV completely and remove debris.
	Bent or broken impeller or ribbon.	Inspect and repair or replace as necessary.
	Impeller support bearing worn out.	Replace bearing as necessary. Properly lube bearing.
	Ribbon hydraulic drive motor(s) damaged.	Inspect and repair or replace as necessary.

HYDRAULIC SYSTEM

Problem	Probable Cause	Corrective Action
Joystick does not operate any components	Low hydraulic oil level	Add oil
One hydraulic function inoperative	Hydraulic lines not connected	Check connections
Ribbon will not rotate	Foreign object is jammed in ribbon	Turn off MSV. Remove object. Do not place hands inside the ribbon area.

Replacement Parts

REPLACEMENT PARTS



390-118352



390-157202



390-140941



390-140940



AVOID INJURY!
SHUT OFF ENGINE AND BE SURE ALL PARTS HAVE STOPPED BEFORE UNBLOCKING DISCHARGE CHUTE.

390-150721

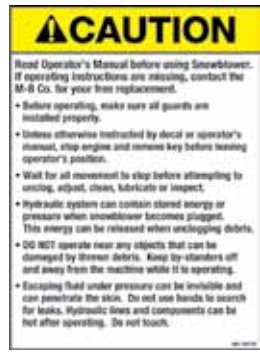

390-150728



390-169221



390-150720

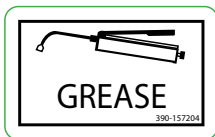

390-157204



390-118349

AUGER WITH REVERSING VALVE

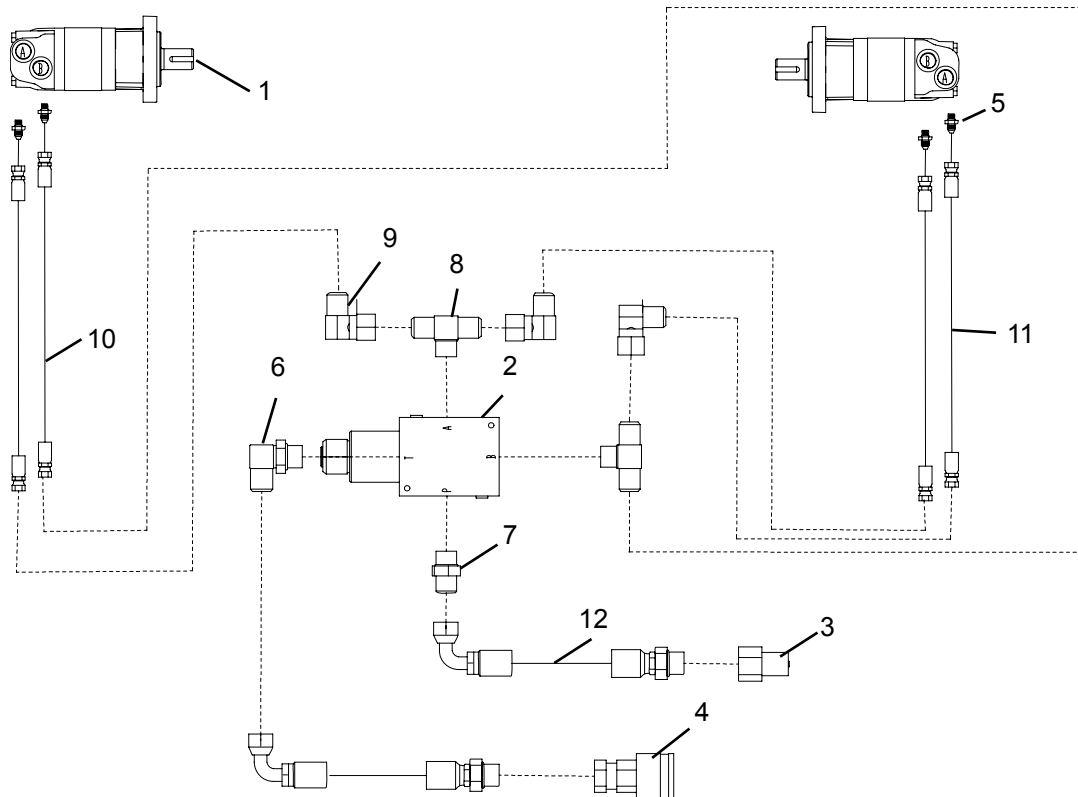

Replacement Parts List

Item	Part Number	Description	QTY
1	201-147189	HYD Motor, Auger 18.71 CI, 1.25 ST Shaft, 5/16 SQ x 1.25 Key, Painted Black	2
2	202-157475	Valve, Reversing, 1-1/16 ORB Ports	1
3	207-144670	Quick Disconnect, 1-1/16 ORB Male Nipple	1
4	207-144672	Quick Disconnect, 1-1/16 ORB Female Coupler	1
5	211-122349	STR ADPT JIC x ORB 7/8 JIC x 7/8 ORB (China Type Only)	4
6	211-41449	Elbow 90 1-1/16 SAE ORB x JIC	1
7	211-51800	Adapter, Straight 1-1/16 ORB 1-1/16 JIC	1
8	211-51804	Branch Tee ORB JIC 1-1/16 ORB 1-1/16 JIC	2
9	211-51805	Elbow 90 JIC SW 1-1/16 JIC	3
10	213-152891	Hose Assy, 5/8" x 64" OAL, -10 JICFSW x -12 JICFSW	2
11	213-152892	Hose Assy, 5/8" x 49" OAL, -10 JICFSW x -12 JICFSW	2
12	213-152894	Hose Assy, 3/4" x 58" OAL, -12 JICSW90 x -12 ORB	2

Parts listed in bold letters are considered to be a Maintenance, Service or Wear part. These parts will generally be stocked by dealers.



AUGER WITHOUT REVERSING VALVE

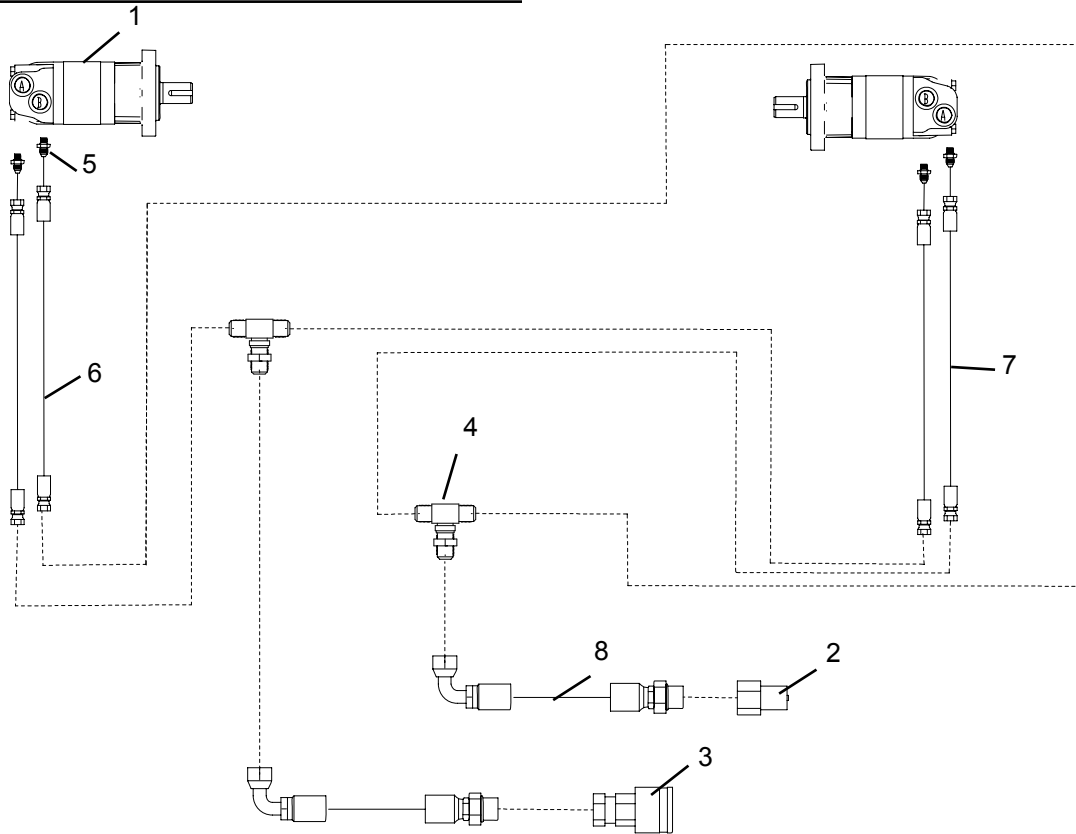

Replacement Parts List

Item	Part Number	Description	QTY
1	201-147189	Hyd Motor, Auger, 18.71 CI, 1.25 ST Shaft, 5/16 SQ x 1.25 Key, Painted Black	2
2	207-144670	Quick Disconnect, 1-1/16 ORB Male Nipple	1
3	207-144672	Quick Disconnect, 1-1/16 ORB Female Coupler	1
4	211-64563	Bulkhead Tee 1-1/16 JIC	2
5	211-122349	STR ADPT JIC x ORB 7/8 JIC x 7/8 ORB (China Type Only)	4
6	213-152891	Hose Assy, 5/8" x 64" OAL, -10 JICFSW x -12 JICFSW	2
7	213-152892	Hose Assy, 5/8" x 49" OAL, -10 JICFSW x -12 JICFSW	2
8	213-152894	Hose Assy, 3/4" x 58" OAL, -12 JICSW90 x -12 ORB	2

Parts listed in bold letters are considered to be a Maintenance, Service or Wear part. These parts will generally be stocked by dealers.

DISCHARGE CHUTE

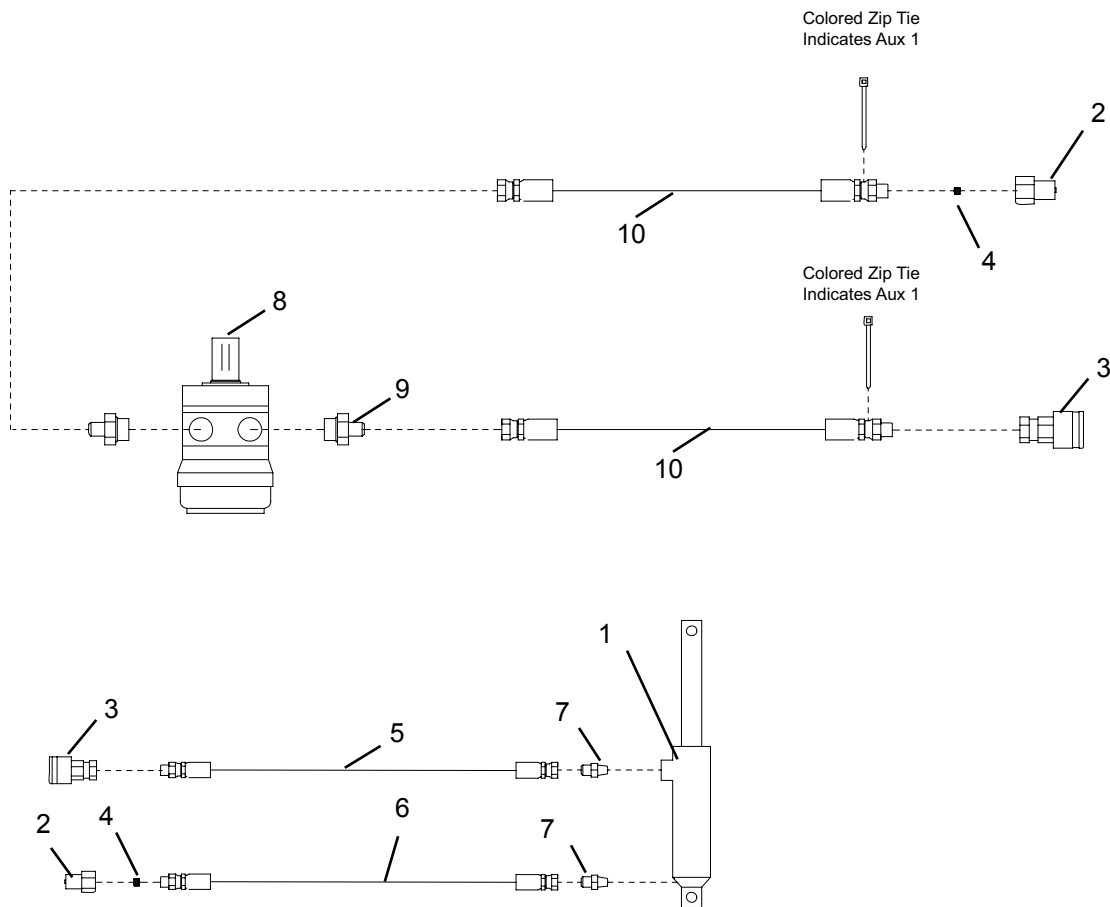

Replacement Parts List			
Item	Part Number	Description	QTY
1	203-143068	Cylinder, Hydraulic 1.50 Bore x 4.00 Stroke, 1/4 NPT Ports	1
2	207-157736	Quick Disconnect, 1/4 F NPT, Male Nipple	2
3	207-157737	Quick Disconnect, 3/4 F NPT, Female Coupler	2
4	211-162019	Orifice, .032, 3/8-16 Thread	2
5	213-152898	Hose Assy, 1/4" ID x 94" OAL 9/16 JICSW 1/4" NPT	1
6	213-152897	Hose Assy, 1/4" ID x 82" OAL, 9/16 JICSW 1/4" NPT - Threaded for Orifice	1
7	211-41360	STR ADPT M Pipe 37 JIC 9/16 JIC 1/4 NPT	2
8	201-143096	Motor, Hydraulic Chute Rotation	1
9	211-51987	STR ADPT 7/8 ORBM, 9/16 JICM	2
10	213-152896	Hose Assy, 1/4" 43 OAL 9/16 JICFSW 1/4 NPTM	2

Parts listed in bold letters are considered to be a Maintenance, Service or Wear part. These parts will generally be stocked by dealers.



SNOWBLOWER WITH PTO

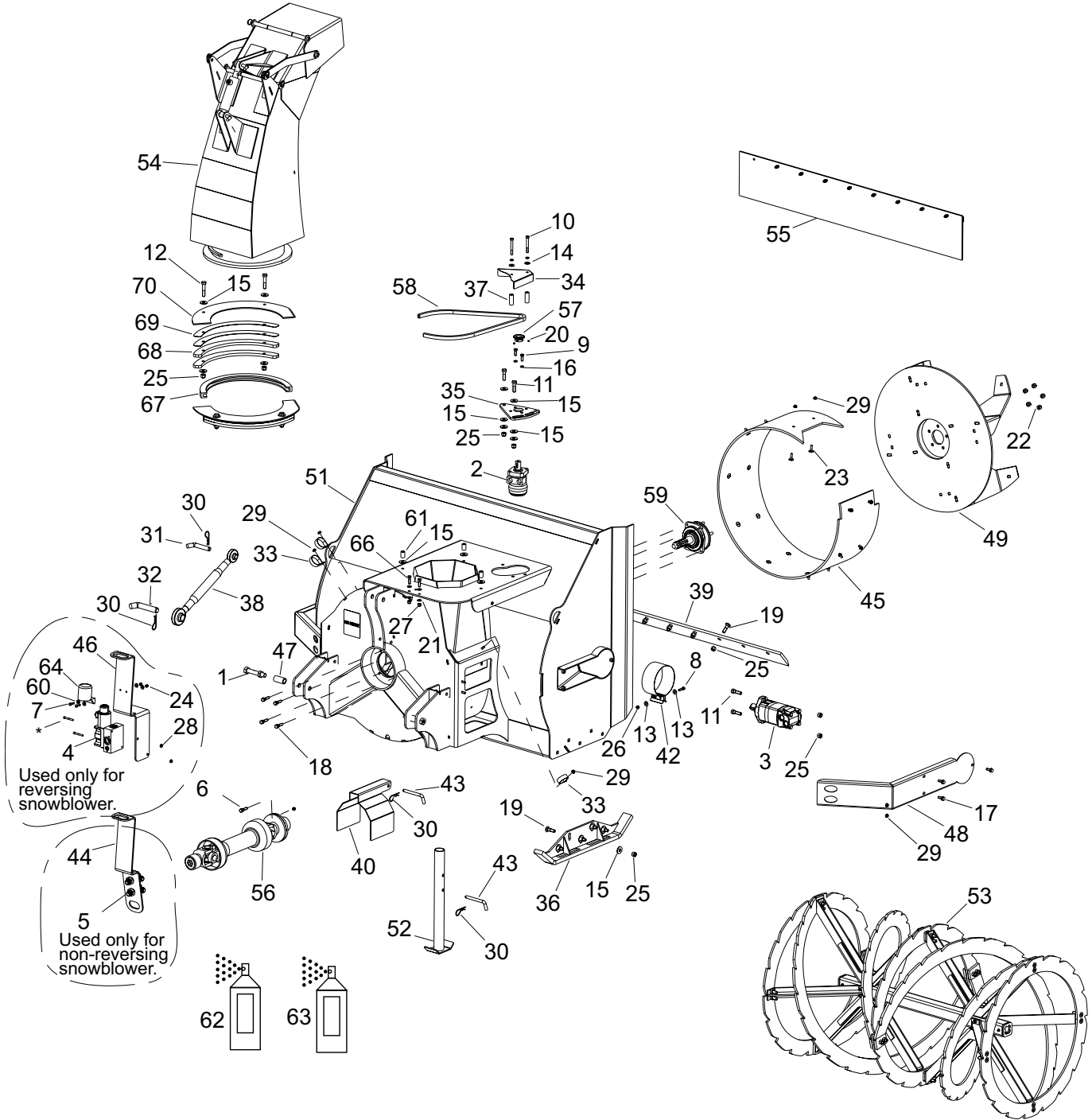

- * SHCS 1/4-20 x 2.00 (Qty 2) comes with valve.
- #56 includes # 6 371-163045 shear bolt and a 3/8 hex nut.
- # 58 includes (2) 508-75408 connecting link #40.



Replacement Parts List			
Item	Part Number	Description	QTY
1	100-157398	Pin, 3/4" x 4-1/4" W/Zirk and Locknut	2
2	201-143096	Motor, Hydraulic Chute Rotation	1
3	201-147189	Hydraulic Motor 18.71 CUI	2
4	202-157475	Reversing Valve 1-1/16 ORB Ports	1
5	211-64563	Bulkhead Tee 1-1/6 JIC	2
6	371-163045	Shear Bolt	1
7	311-10750	HHCS .25-20 UNC x 1.000	2
8	311-21250	HHCS .31-18 UNC x 1.250	4
9	311-31000	HHCS 3/8-16 UNC x 1.000	2
10	311-33000	HHCS 3/8-16 UNC x 3.000	2
11	311-51750	HHCS .50-13 UNC x 1.750	6
12	311-52500	HHCS .50-13 UNC x 2.500	4
13	341-20000	Washer, Flat - 5/16 STD Zinc PL	8
14	341-30000	Washer, Flat - 3/8 STD Zinc PL	2
15	341-50000	Washer, Flat - 1/2 STD Zinc PL	27
16	351-30000	Washer, Lock - 3/8 YLW Zinc PL	8
17	370-126977	HHCS, Serrated Flange 3/8-16 x 1 Plated	6
18	370-133201	MHHCS M10 x 1.5 x 40	4
19	370-84609	Carriage Bolt 1/2-13 UNC x 1.75	19
20	370-98795	Setscrew, Allen HD 1/4-20 x .25	2
21	343-30000	Washer SAE 3/8	4
22	371-152871	Nut, Lug M12 x 1.5	5
23	371-152878	Bolt, Elevator - 5/16	16
24	371-81299	Nut, Hex, ESNA, 1/4-20 NC	2
25	371-81417	Nut, Hex, ESNA, 1/2-13 UNC	33
26	371-81620	Nut, Hex, ESNA, 5/16-18 UNC	4
27	371-81297	Nut, Hex, ESNA, 3/8-16 UNC	2
28	371-92058	Nut, Flanged 1/4-20 Plated Locking	2
29	371-92059	Nut, Flanged 5/16-18 Plated Locking	23
30	380-84739	Pin, Hair Clip #11	4
31	383-122610	Pin, Hitch, Bent Pull 3/4 x 3 1/2 Grip LG	1
32	383-132433	Pin, Hitch Bent 1 x 4-3/4 Grip LG	1
33	387-92072	Cable Clamp 2 ID	3
34	401-143022	Guard, Chain Black	1
35	401-157702	Bracket, Motor Mount	1
36	410-152807	Weldment, Skid Shoe	2
37	401-143117	Spacer, Chain Guard	2
38	401-152698	Top Link, MSV CAT 1 & 2, 12" Body	1
39	401-163543	Edge, Cutting See Table 1	1



Replacement Parts List			
Item	Part Number	Description	QTY
40	401-152772	Guard, PTO Snowblower	1
42	401-152859	Shield, Hydraulic Motor	2
43	383-147693	Pin, Hitch 1/2 x 4.0 Rear	2
44	401-152873	Support, Hose	1
45	401-152885	Liner, Poly Impeller Housing	1
46	401-157371	Support, Hose Reversing Valve Mount	1
47	401-157399	Tube 1-1/8 OD x 3/4 ID x 2-1/4	2
48	See Table 1,	Weldment, Side Cover Snowblower, MSV	2
49	410-152802	Weldment, Impeller	1
51	See Table 1,	Weldment, Moldboard	1
52	410-152866	Weldment Support Stand	1
53	See Table 1,	Ribbon Assembly	1
54	420-152803	Chute Assembly	1
55	See Table 1,	Kit, Snow Flap	1
56	502-152804	Assembly, PTO	1
57	506-143078	Gear, Chute Rotation	1
58	508-152879	Chain, Roller #40-52 IN	1
59	430-97537	Assy, Hub Bearing	1
60	341-10000	Washer, Flat, 1/4 STD Zinc Pl	4
61	603-147195	Bushing, Plain Oilite	3
62	109-131128	Yellow Touch-up Paint	
63	249-92005	Primer, Aerosol Can	
64	703-92194	Stor-A-Way Holder	1
66	311-31250	HHCS 3/8-16 UNC x 1.250	2
67	401-157348	Chute Bearing	1
68	401-162034	Keeper, Bearing	4
69	401-162052	Shim, Chute HP	4
70	401-162035	Plate, Bearing, Chute HP	2
*	721-157400	Harness -Reversing Valve	1

*Not Shown

Parts listed in bold letters are considered to be a Maintenance, Service or Wear part. These parts will generally be stocked by dealers.

Table 1:

Snowblower	51"	60"
Edge, Cutting	401-152808	401-163543

Snowblower	51"	60"
Side Cover	410-152799	410-163540
Moldboard	410-152810	410-163531
Ribbon	420-152801	420-163545
Kit, Flap	420-152884	420-163547

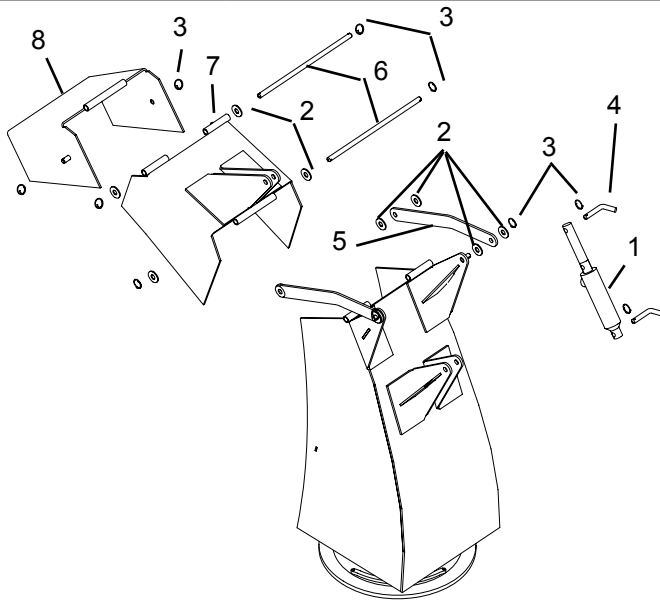

420-152803 chute assembly includes items listed below.

Replacement Parts List			
Item	Part Number	Description	QTY
1	203-143068	Cylinder, Hydraulic	1
2	341-50000	Washer, Flat - 1/2 STD Zinc PL	12
3	380-162079	Ring, Cotter, For 7/16-1/2 Pin	10
4	383-122609	Pin, Hitch, Bent Pull 1/2 x 2 1/2 Grip LG	2
5	401-152851	Chute, Linkage	2
6	401-152853	Rod, Hinge Chute	2
7	410-152841	Weldment, Chute Center	1
8	410-152842	Chute Top Weldment	1

Parts listed in bold letters are considered to be a Maintenance, Service or Wear part. These parts will generally be stocked by dealers.



HYDRAULIC FITTING INSTALLATION TORQUE RECOMMENDATION

Table 2: For 37° & 45° (Machined or Flared) and MegaSeal®

Size		Steel				Brass			
Dash	Fractional (In.)	Ft-Lbs.		Newton-Meters		Ft-Lbs.		Newton-Meters	
		Min.	Max.	Min.	Max.	Min.	Max.	Min.	Max.
-4	1/4	10	11	13	15	5	6	6-3/4	9
-5	5/16	13	15	18	20	7	9	10	13
-6	3/8	17	19	23	26	12	15	17	20
-8	1/2	34	38	47	52	20	24	27-2/3	33
-10	5/8	50	56	69	76	34	40	46-1/3	55
-12	3/4	70	78	96	106	53	60	72-1/3	82
-16	1	94	104	127	141	74	82	100-1/2	111
-20	1-1/4	124	138	169	188	75	83	101-1/2	113
-24	1-1/2	156	173	212	235	79	87	107	118
-32	2	219	243	296	329	158	175	214	237

Table 3: For Flat-Face “O” Ring Seal (Steel)

Size		Ft-Lbs.		Newton-Meters	
Dash	Fractional (In.)	Min.	Max.	Min.	Max.
-4	1/4	10	12	14	16
-6	3/8	18	20	24	27
-8	1/2	32	40	43	54
-10	5/8	46	56	60	75
-12	3/4	65	80	90	110
-14	7/8	65	80	90	110
-16	1	92	105	125	240
-20	1-1/4	125	140	170	190
-24	1-1/2	150	180	200	245



Table 4: For SAE O-Ring Boss (Steel) & Gates Adapterless

Size		Ft-Lbs. Working Pressures 4,000 psi (27.5 Mpa) and below		Newton-Meters Working Pressures 4,000 psi (27.5 Mpa) and below		Ft-Lbs. Working Pressures Above 4,000 psi (27.5 Mpa)		Newton-Meters Working Pressures Above 4,000 psi (27.5 Mpa)	
Dash	Fractional (In.)	Min.	Max.	Min.	Max.	Min.	Max.	Min.	Max.
-3	3/16	—	—	—	—	8	10	11	13
-4	1/4	14	16	20	22	14	16	20	22
-5	5/16	—	—	—	—	18	20	24	27
-6	3/8	24	26	33	35	24	26	33	35
-8	1/2	37	44	50	60	50	60	68	78
-10	5/8	50	60	68	81	72	80	98	110
-12	3/4	75	83	101-1/2	113	125	135	170	183
-14	7/8	—	—	—	—	160	180	215	245
-16	1	111	125	150	170	200	220	270	300
-20	1-1/4	133	152	180	206	210	280	285	380
-24	1-1/2	156	184	212	250	270	360	370	490

Table 5: Maximum Recommended Torque for dry NPTF (Tapered) Pipe Threads*

Size	Ft-Lbs.	Newton-Meters
-2	20	25
-4	25	35
-6	35	45
-8	45	60
-12	55	75
-16	65	90
-20	80	110
-24	95	130
-32	120	160

***NOTES:**

1. The torque values obtained from tightening pipe threads can vary considerably depending on thread condition. Adequate sealing can occur at values much lower than the maximum values listed above. Only enough torque to achieve adequate sealing should be used.
2. When using a male tapered pipe thread with a female straight or parallel pipe thread, maximum values are 50% of those listed in the table.
3. If threaded sealant is used, maximum values shown should be decreased by 25%



FASTENER TORQUE RECOMMENDATION

Table 6: Torque for Standard Fasteners









Nominal Dia.	Threads per inch	 Grade 2			 Grade 5			 Grade 8			 Grade 9		
		Tightening Torque			Tightening Torque			Tightening Torque			Tightening Torque		
		Lubed	Dry Plated	Dry Plain	Lubed	Dry Plated	Dry Plain	Lubed	Dry Plated	Dry Plain	Lubed	Dry Plated	Dry Plain
(in.)		K = 0.15	K = 0.17	K = 0.20	K = 0.15	K = 0.17	K = 0.20	K = 0.15	K = 0.17	K = 0.20	K = 0.15	K = 0.17	K = 0.20
Unified Coarse Thread Series													
1/4	20	49 in-lbs	59 in-lbs	66 in-lbs	76 in-lbs	86 in-lbs	101 in-lbs	107 in-lbs	122 in-lbs	143 in-lbs	126 in-lbs	143 in-lbs	168 in-lbs
5/16	18	101	122	135	157	178	209	221	251	295	259	294	346
3/8	16	15 ft-lbs	18 ft-lbs	20 ft-lbs	23 ft-lbs	26 ft-lbs	31 ft-lbs	33 ft-lbs	37 ft-lbs	44 ft-lbs	38 ft-lbs	43 ft-lbs	51 ft-lbs
7/16	14	24	29	32	37	42	49	52	59	70	61	70	82
1/2	13	37	44	49	57	64	75	80	90	106	94	106	125
9/16	12	53	63	70	82	92	109	115	130	154	135	153	180
5/8	11	73	87	97	113	126	150	159	180	212	186	211	248
3/4	10	129	155	172	200	227	267	282	320	376	331	375	441
7/8	9	125	160	167	322	365	429	455	615	606	633	604	710
1	8	187	225	250	483	547	644	681	722	909	799	905	1065
1-1/8	7	266	319	354	596	675	794	966	1095	1288	1132	1283	1510
1-1/4	7	375	450	500	840	952	1121	1363	1545	1817	1597	1810	2130
1-1/2	6	652	783	869	1462	1657	1950	2371	2688	3162	2779	3150	3706
Fine Thread Series													
1/4	28	56 in-lbs	68 in-lbs	75 in-lbs	87 in-lbs	99 in-lbs	116 in-lbs	123 in-lbs	139 in-lbs	164 in-lbs	144 in-lbs	163 in-lbs	192 in-lbs
5/16	24	112	135	150	174	197	231	245	278	327	287	325	383
3/8	24	17 ft-lbs	20 ft-lbs	23 ft-lbs	26 ft-lbs	30 ft-lbs	35 ft-lbs	37 ft-lbs	42 ft-lbs	49 ft-lbs	43 ft-lbs	49 ft-lbs	58 ft-lbs
7/16	20	27	32	36	41	47	55	58	66	78	68	78	91
1/2	20	41	49	55	64	72	85	90	102	120	105	120	141
9/16	18	59	71	78	91	103	121	126	146	171	151	171	201
5/8	18	82	99	110	127	144	170	180	204	240	211	239	281
3/4	16	144	173	192	223	253	297	315	357	420	369	418	492
7/8	14	138	165	184	355	403	474	502	568	669	588	666	784
1	14	210	252	280	542	614	722	765	867	1020	896	1016	1195
1-1/8	12	298	357	397	668	757	890	1083	1227	1444	1269	1439	1693
1-1/4	12	415	493	553	930	1055	1241	1509	1710	2012	1768	2004	2358
1-1/2	12	734	880	978	1645	1865	2194	2668	3024	3557	3127	3544	4169
<p>Torque values for 1/4 and 5/16-in series are in inch-pounds. All other torque values are in foot-pounds Torque values calculated from formulas $T=KDF$, where K = 0.15 for "lubricated" conditions K = 0.17 for zinc plated and dry conditions K = 0.20 for plain and dry conditions D = Nominal Diameter F = Clamp Load</p>													

Table 7: Torque-Tension Relationship for Metric Fasteners

Nominal Dia.	Pitch	 Class 4.6			 Class 8.8			 Class 10.9			 Class 12.9	
		Tightening Torque			Tightening Torque			Tightening Torque			Tightening Torque	
		Lubed	Dry Plated	Dry Plain	Lubed	Dry Plated	Dry Plain	Lubed	Dry Plated	Dry Plain	Lubed	Dry Plain
		K = 0.15 (ft-lbs)	K = 0.17 (ft-lbs)	K = 0.20 (ft-lbs)	K = 0.15 (ft-lbs)	K = 0.17 (ft-lbs)	K = 0.20 (ft-lbs)	K = 0.15 (ft-lbs)	K = 0.17 (ft-lbs)	K = 0.20 (ft-lbs)	K = 0.15	K = 0.20
(mm)												
3	0.5	0.28	0.32	0.38	0.73	0.82	0.97	1.0	1.2	1.4	1.2	1.6
3.5	0.6	0.44	0.50	0.59	1.1	1.3	1.5	1.6	1.9	2.2	1.9	2.5
4	0.7	0.66	0.74	0.87	1.7	1.9	2.3	2.4	2.7	3.2	2.8	3.8
5	0.8	1.3	1.5	1.8	3.4	3.9	4.5	4.9	5.5	6.5	5.7	7.6
6	1	2.3	2.6	3.0	5.8	6.6	7.7	8.3	9.4	11	9.7	13
6	1.25	2.1	2.3	2.7	5.3	6.0	7.0	7.6	8.6	10	8.8	12
7	1	3.8	4.3	5.0	9.7	11	13	14	16	19	16	22
8	1	5.9	6.6	7.8	15	17	20	22	24	29	25	34
8	1.25	5.5	6.2	7.3	14	16	19	20	23	27	24	31
10	1.25	11	13	15	29	33	39	42	48	56	49	66
10	1.5	11	12	14	28	32	37	40	45	53	47	62
12	1.25	21	23	28	53	60	71	76	86	101	89	119
12	1.5	20	22	26	51	58	68	73	82	97	85	113
12	1.75	19	21	25	49	55	65	70	79	93	81	108
14	1.25	26	29	34	66	75	89	95	106	127	111	148
14	1.5	28	32	37	72	82	96	103	117	138	121	161
14	2	30	34	40	78	88	104	111	126	148	130	173
16	1.5	50	57	67	129	146	171	184	208	245	215	287
16	2	47	53	62	121	137	161	173	196	230	202	269
18	1.5	73	82	97	187	212	249	266	303	357	313	417
18	2.5	65	73	86	167	189	222	239	270	318	279	372
20	2.5	91	104	122	236	267	314	337	382	449	394	525

Clamp load calculated as 75% of the proof load for specified bolts.
 All Torque values are listed in foot-pounds
 Torque values calculated from formulas $T=KDF$, where
 K = 0.15 for "lubricated" conditions
 K = 0.17 for zinc plated and dry conditions
 K = 0.20 for plain and dry conditions
 D = Nominal Diameter
 F = Clamp Load



Torque wrenches may have an adapter attached to help reach a bolt or nut. Use the following formula to recalculate the reading of the torque wrench.

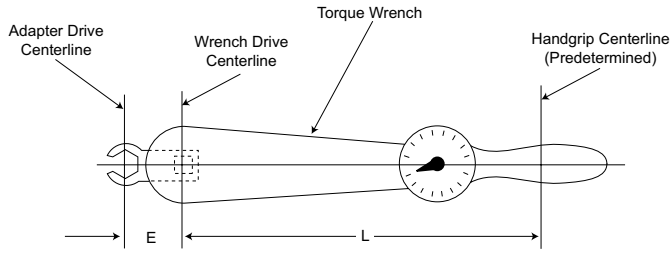

$$\text{Formula: } \frac{T \times L}{L + E} = Y$$

Example: (with "E" as plus dimension)

Desired Torque $T = 135 \text{ lb. In.}$
 $Y = \text{Unknown}$
Original Length $L = 10.0 \text{ In.}$
Extension $E = 1.5 \text{ In.}$

$$Y = \frac{135 \times 10}{10 + 1.5} = \frac{1350}{11.5} = 117.39$$

$Y = 117 \text{ lb In.}$
Final reading on torque wrench

Figure 44

Other Products from M-B/Warranty

Visit www.M-BCO.com to view all M-B Companies exciting Products.

Manufacturer's Limited Warranty

The M-B Companies, Inc. warrants all its M-B MSV products to be free from defects in materials and workmanship for 12 months, to begin with the delivery of said product to its original owner. This warranty is not transferable without the written consent of M-B.

M-B will, at its own expense and without expense to the owner, replace all failed parts for and make all repairs that may be required by reason of workmanship or material in any part of the assembly of the product and associated components.

Upon notice in writing, M-B will promptly repair or replace all defective or damaged items delivered under the contract. The batteries, tires, rubber materials, brushes and material normally consumed in operation, and major components such as engines, air compressors, and hydraulic pumps and motors are excluded from this warranty but shall, in any event, be guaranteed by M-B to the extent of any warranty received from its supplier.

Any components replaced under warranty will be warranted for the remainder of the original warranty. Replaced components do not restart the warranty period.

If requested by M-B, products or parts for which a warranty claim is made are to be returned, transportation prepaid, to M-B's factory. Any improper use, operation beyond capacity, or substitution of parts not approved by M-B, or alteration or repair by others in such a manner as in M-B's judgement materially and/or adversely affects the product shall void this warranty.

This warranty does not apply to defects caused by damage or unreasonable use while in the possession of the owner, including but not limited to: failure to provide reasonable and necessary maintenance, normal wear, routine tune-ups or adjustments, improper handling or accidents, operation at speed or load conditions contrary to published specifications, improper or insufficient lubrication, or improper storage.

The M-B Companies, Inc. shall not be liable for consequential damages of any kind, including, but not limited to, consequential labor costs or transportation charges in connection with the replacement or repair of defective parts, or lost time or expense which may have accrued because of said defect.

THE M-B COMPANIES DO NOT MAKE ANY WARRANTY OF MERCHANTABILITY OR OF FITNESS FOR A PARTICULAR PURPOSE. THE ONLY WARRANTY MADE BY M-B COMPANIES IS AS SET FORTH HEREIN. THIS WARRANTY CANNOT BE EXTENDED, BROADENED OR CHANGED EXCEPT IN WRITING BY AN AUTHORIZED OFFICER OF M-B COMPANIES, INC.

(M-B's total liability hereunder in no event shall exceed the purchase price of the product.)